

# SL™ Series



Now available in white. Perfect for churches, retail stores, museums, convention centers, lecture halls or hotels.

## Standard Features

- SL strips to be used for fixed installations.
- Up to sixteen (16) 20 Amp circuits
- Black extruded aluminum wireway with interlocking cover sections to exceed UL 1573 standards.
- 15, 20, 30, 50, and 60 Amp connectors and receptacles available.
- Flush receptacles or 18" pigtail mounted connectors.
- Pre-wired with 125° C XLP high temperature wire to molded barrier terminal blocks.
- Terminal blocks can accept up to #10 gauge wire.
- 2" white die-cut circuit identification.
- Supplied with standard mounting brackets.
- UL listed and labeled.

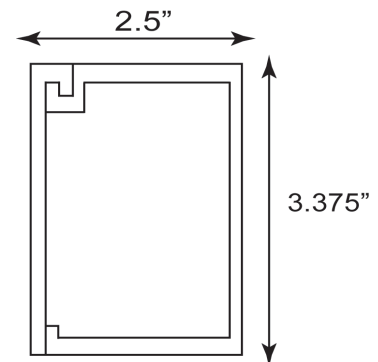

## Optional Features

- Custom colors.
- LED indicator lights.
- Low voltage raceway.
- Custom circuit identification.
- Custom mounting brackets.
- Feed through wiring.
- DMX input/output.

